

CHAPTER 4 PART REFERENCE

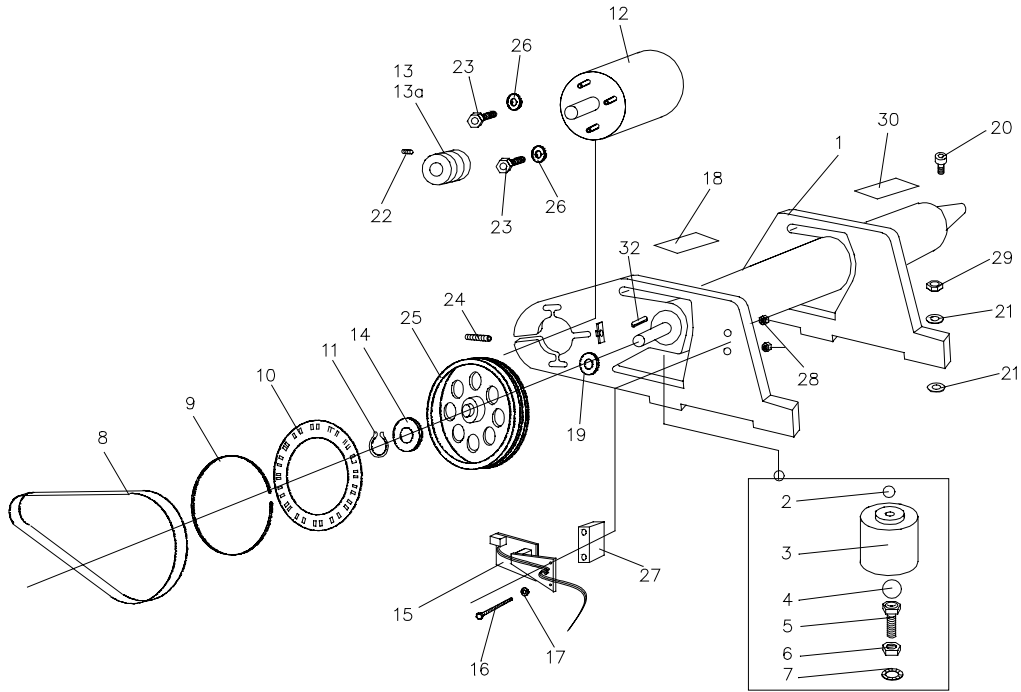

Drive Suspension Assembly

ITEM	DESCRIPTION	PART NUMBER	ITEM	DESCRIPTION	PART NUMBER
1	Suspension Weldment	H6415529	16	HH Bolt, Encoder	H2001099
2	Ball Bearing – 6mm dia.	H1317060	17	Washer	H2001041
3	Transducer	H6410509	18	Warning Label	H3300010
4	Ball Bearing–15mm dia.	H1317150	19	Washer	H2001098
5	Adj. Screw, transducer	H1530121A	20	Allen Screw, M10	H1524077
6	M10 Hex Nut	H1556100	21	Washer, 10.5mm	H1643610
7	M10 Lockring	H1647100	22	Set Screw, 5/16x18x0.5"	H2001023
8	Drive Belt	H3300017HD	23	Motor Mount, Special	H3300025
9	Circular Spring	H1614009	24	Set Screw, 3/8x16x1.5"	H2001107
10	Encoder Disc	H1648953	25	Drive Pulley	H6411559
11	Circlip	H1659025	26	Washer, 3/8"	H2001050
12	Motor, 230VAC 1Ph.	H41042806	27	Spacer Block, Encoder	H3300059
13	Motor Pulley	H6415551-1	28	Lock Nut	H2001040
14	Washer, 25x35x2mm	H1645130	29	Nut, M10	H1555100
15	Encoder	H6704143	30	Warning Label	H3300008

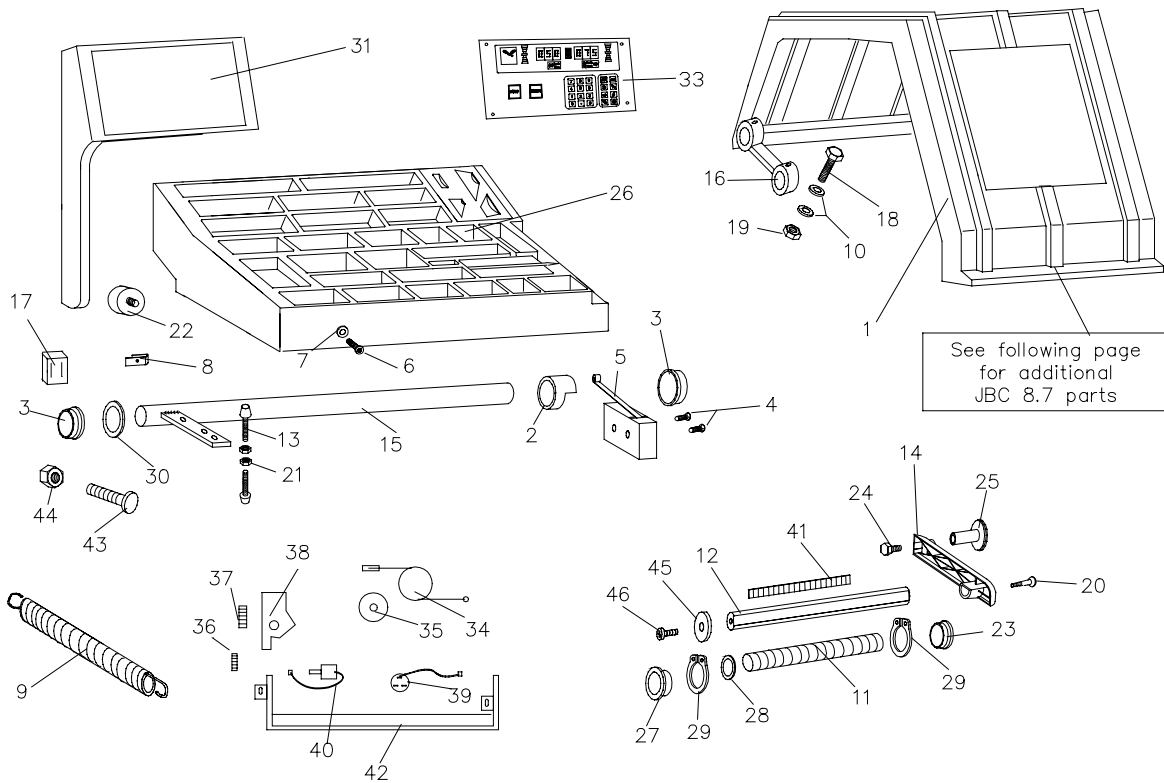

Exploded View

ITEM	DESCRIPTION	PART NUMBER	ITEM	DESCRIPTION	PART NUMBER
1	Wheel Guard, 8.6	H6000002	24	Hex Screw, M10x20mm	H1530117
2	Trip Cam	H1631040	25	Distance Gauge Finger	H9500009
3	Collar and Bushing	H1324032	26	Weight Tray	H6000003
4	Ch.Hd. Screw, M4x10	H1529021	27	Bushing	H1701356
5	Wheel Guard Switch	H4402102	28	Spacer	H1645124
6	Screw, ¼-20x ¾"	H3300052	29	Circlip	H1657027
7	Washer, ¼"	H2001041	30	Steel Washer	H1701012
8	Panel (Clip) Nut, ¼-20	H3300053	31	Display Enclosure	H6000004
9	Spring	H1621176	33	Front Panel Assembly	H8600001
10	Washer, 10.5mm	H1641100	34	Fine Wire Rope	H1230801
11	Compression Spring	H1613224	35	Roller (Pulley)	H1230901
12	Distance Gauge Rod	H1040901	36	Gear Wheel, Potentiometer	H1235528
13	Wheel Guard Stop, int.	H1745207	37	Gear Wheel, Shaft	H1235533
14	Distance Gauge Lever	H6411262	38	Carriage	H1701009
15	Wheel Guard Shaft	H6413153	39	Distance Potentiometer	H6790493
16	Wheel Guard Brkt, 8.6	H3300001	40	Diameter Potentiometer	H6790494
17	OFF / ON Switch	H3300022	41	Distance Gauge Decal	H4082727
18	HH Bolt, M10x60mm	H1530128	42	Bracket	HS4135031
19	Self Locking Nut, M10	H1557101	43	Wheel Guard Stop, Ext.Adj.	H3300056
20	Self Tapping Screw	H2001016	44	Half Nut, M8	H1552080
21	Nut, M6	H1555060	45	Washer, M8	H1640080
22	Calibration Weight	H6413155	46	Self Tap Screw, M6x12mm	H1532662
23	Bushing	H1701355			

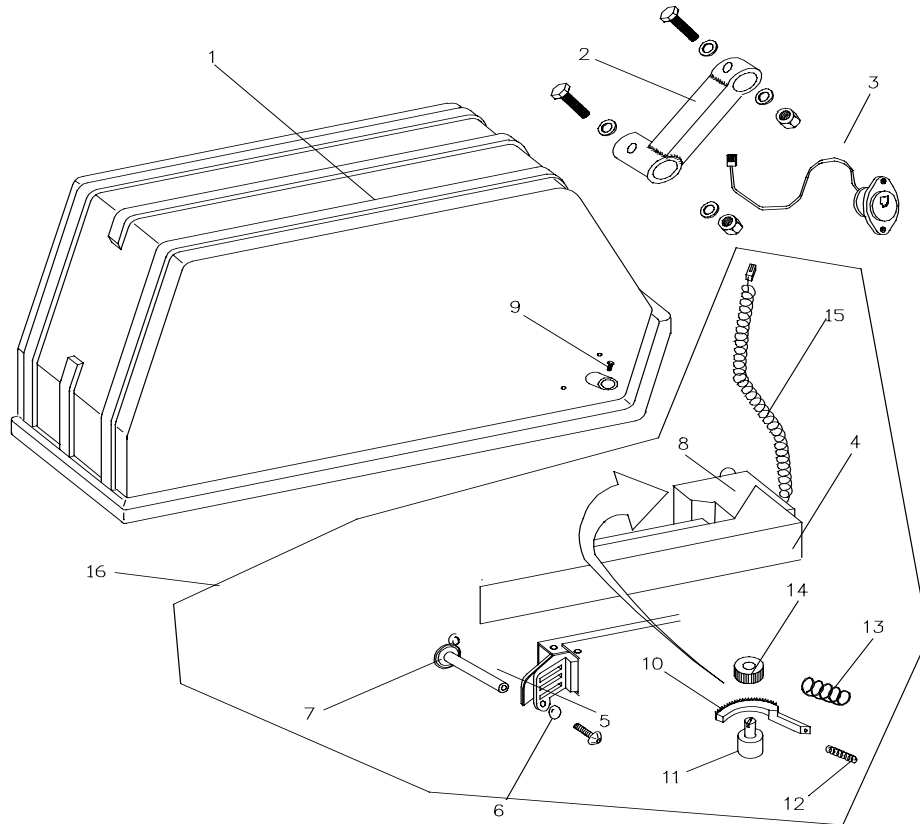

Wheel Guard Assembly

ITEM	DESCRIPTION	PART NUMBER	ITEM	DESCRIPTION	PART NUMBER
1	Wheel Guard, 8.7	H6000002A	9	Allen Screw, M8x16mm	1535060
2	Wheel Guard Brkt., 8.7	3300001/HD	10	Tooth Segment 8.7	H1701553
3	Rim Width Cable Conn.	H9500003A	11	Width Potentiometer, 10k	H3870633
4	Rim Width Gauge Arm	H9500001A	12	Tension Spring	H1621083
5	Button Head Screw	H2001108	13	Leg Spring	H1614015
6	Washer, 8.4 mm	H1641080	14	Gear Wheel	H1235535
7	Width Gauge Finger	H9500008	15	Extension Cord 8.7	H9500007
8	Joined Head	H1701552	16	Parameter entry Arm assy'	H9500001A

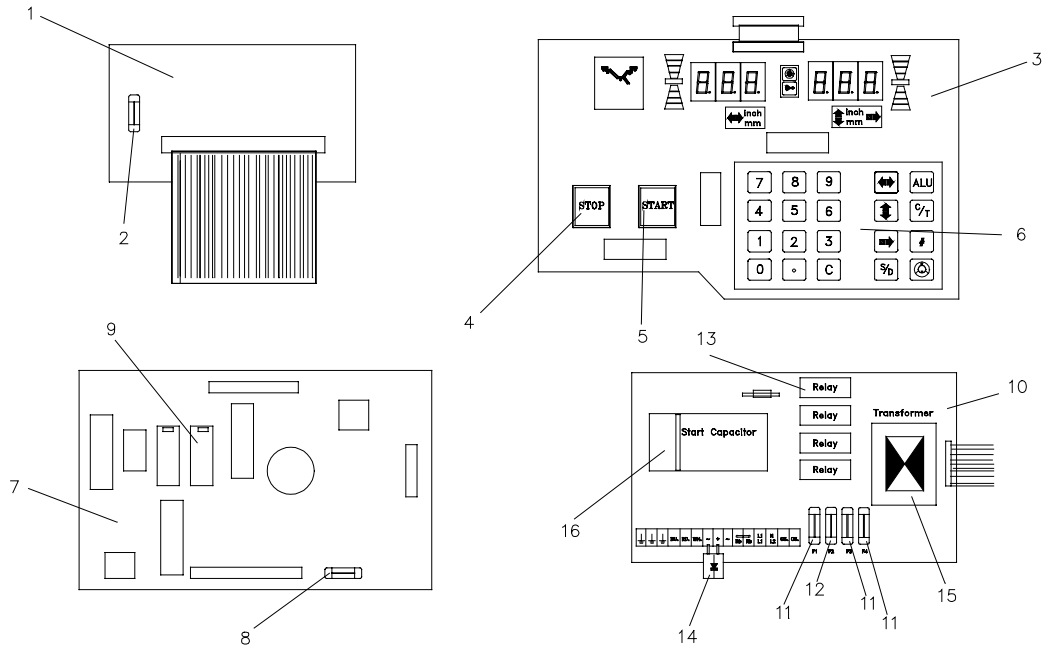

PCB View

ITEM	DESCRIPTION	PART NUMBER	ITEM	DESCRIPTION	PART NUMBER
1	Interface PCB	H67263372	9	EPROM Set	H67400954
2	Interface PCB Fuse .8A	H3350113	10	Motor/Electric Control PCB	H67263654
3	Display PCB	H67263521	11	Fuse, 12A-250V Quick Act.	H10010364
4	STOP Key	H3402247	12	Fuse, .4A-250V Quick Act.	H10010352
5	START Key	H3402246	13	Relay	H3440068
6	Main Key Pad	H3402245	14	Location Brake Device	H3300050
7	Processor PCB	H6726320	15	Transformer, 230-21VAC	H35014352
8	Processor Fuse, 1A SB	H3350312	16	Start Cap, 43-52 μ F, 330V	H3762010/4

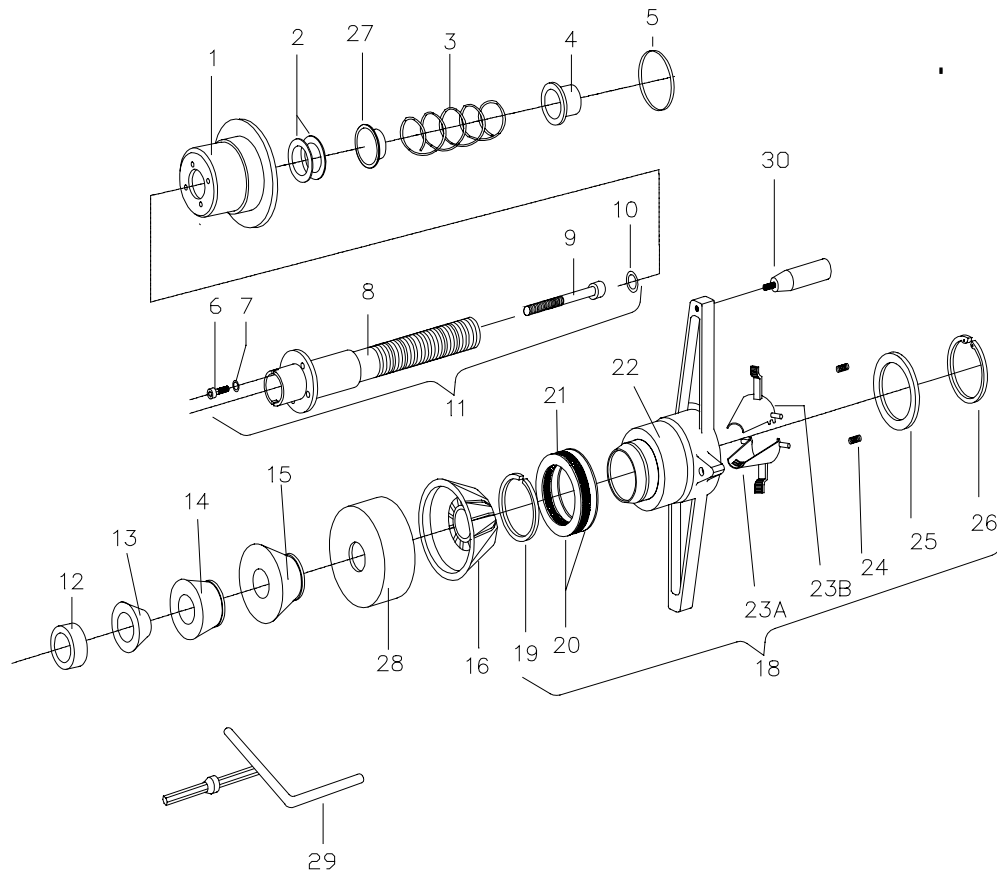

Centering Device Exploded View

ITEM	DESCRIPTION	PART NUMBER	ITEM	DESCRIPTION	PART NUMBER
1	Backing Plate	H6411234	16	Clamping Hood	00112301000
2	Washer	H1645047	18	Quick-Nut Clamping Assy.	00112298000
3	Compression Spring	H1611341	19	Snap Ring	H1656052
4	Spring Casing	H1098001	20	Thrust Spacer Ring	H1645154
5	Snap Ring	H1655092	21	Fiber Disc, Sliding	H1323600
6	HSH Cap Screw	H1524043	22	Wingnut Body	H6409018
7	Lock Washer	H1654060	23	Clamp Jaws, Set	7409019 7409020
8	Threaded Shaft (only)	H6414698	24	Compression Spring, Jaws	H1611128
9	HSH Cap Screw	H1524149	25	Disc, Spring Seat	H1645148
10	Circlip	H1659901	26	Circlip	H1658060
11	Threaded Shaft Assy.	H6415195	27	Spring Centering Ring	H1701409
12	Spacer Ring	00112300000	28	Alloy Wheel Protective Ring	00112296000
13	Sm. Cone, 41-74mm	00112302000	29	Special Hex Wrench, 14mm	00112297000
14	Med. Cone, 71-96mm	00112303000	30	Handle	00111333000
15	Large Cone, 93-116mm	00112304000			

PARTS IN ALPHABETICAL ORDER

<u>DESCRIPTION</u>	<u>PART NUMBER</u>	<u>COMMENTS</u>
Adj. Screw, transducer	1530121/A	
Allen Screw, M10	1524077	
Allen Screw, M8x16mm	1535060	
Alloy Wheel Protective Ring	112296	
Ball Bearing – 6mm dia.	1317060	
Ball Bearing–15mm dia.	1317150	
Bracket	S413503/1	
Bushing	1701355	
Bushing	1701356	
Button Head Screw	2001108	
Calibration Weight	6413155	
Carriage	1701009	
Ch.Hd. Screw, M4x10	1529021	
Circlip	1659025	
Circlip	1657027	
Circlip	1658060	
Circular Spring	1614009	
Clamp Jaws, Set	7409019 7409020	
Clamping Hood	112301	
Collar and Bushing	1324032	
Compression Spring	1613224	
Compression Spring, Jaws	1611128	
Diameter Potentiometer	6790494	
Disc, Spring Seat	1645148	
Display Enclosure	6000004	
Display PCB	6726352-1	
Distance Gauge Decal	4082727	
Distance Gauge Finger	9500009	
Distance Gauge Lever	6411262	
Distance Gauge Rod	1040901	
Distance Potentiometer	6790493	
Drive Arm	1701553	
Drive Belt	3300017/hd	
Drive Pulley	6411559	
Encoder	6704143	
Encoder Disc	1648953	
EPROM Set	6740095-4	
EPROM Set	6740095-4	
Fiber Disc, Sliding	1323600	
Fine Wire Rope	1230801	
Front Panel Assembly	6000001/A	
Fuse, .4A-250V Quick Act.	1001035/2	
Fuse, .4A-250V Quick Act.	1001035/2	
Fuse, 12A-250V Quick Act.	1001036/4	
Fuse, 12A-250V Quick Act.	1001036/4	
Gear Wheel	1235535	
Gear Wheel, Potentiometer	1235528	
Gear Wheel, Shaft	1235533	
Half Nut, M8	1552080	
Handle	112312	
Hex Screw, M10x20mm	1530117	
HH Bolt, Encoder	2001099	
HH Bolt, M10x60mm	1530128	
Interface PCB	6726337-2	

DESCRIPTION	PART NUMBER	COMMENTS
Interface PCB Fuse .8A	3350113	
Joined Head	1701552	
Leg Spring	1614015	
Location Brake Device	3300050	
Location Brake Device	3300050	
Lock Nut	2001040	
M10 Hex Nut	1556100	
M10 Lockring	1647100	
Main Key Pad	3402245	
Motor Mount, Special	3300025	
Motor Pulley	6415551-1	
Motor, 230VAC 1Ph.	4104280/6	
Motor/Electric Control PCB	6726365/4	
Motor/Electric Control PCB	6726365/4	
Nut, M10	1555100	
Nut, M6	1555060	
OFF / ON Switch	3300022	
Panel (Clip) Nut, ¼-20	3300053	
Processor Fuse, 1A SB	3350312	
Processor PCB	6726320	
Quick-Nut Clamping Assy.	112298	
Relay	3440068	
Relay	3440068	
Rim Width Cable Conn.	9500003/A	
Rim Width Gauge Arm	9500001/A	
Rim Width Gauge Finger	9500008	
Roller (Pulley)	1230901	
Screw, ¼-20x ¾"	3300052	
Self Locking Nut, M10	1557101	
Self Tap Screw, M6x12mm	1532662	
Self Tapping Screw	2001016	
Set Screw, 3/8x16x1.5"	2001107	
Set Screw, 5/16x18x0.5"	2001023	
Snap Ring	1656052	
Spacer	1645124	
Spacer Block, Encoder	3300059	
Special Hex Wrench, 14mm	112297	
Spring	1621176	
Spring Centering Ring	1701409	
Start Cap, 43-52µF, 330V	3762010/4	
Start Cap, 43-52µF, 330V	3762010/4	
START Key	3402246	
Steel Washer	1701012	
STOP Key	3402247	
Suspension Weldment	6415529	
Tension Spring	1621083	
Thrust Spacer Ring	1645154	
Transducer	6410509	
Transformer, 230-21VAC	3501435/2	
Transformer, 230-21VAC	3501435/2	
Trip Cam	1631040	
Warning Label	3300010	
Warning Label	3300008	
Washer	2001041	
Washer	2001098	
Washer, ¼"	2001041	

CHAPTER 4 - PARTS

<u>DESCRIPTION</u>	<u>PART NUMBER</u>	<u>COMMENTS</u>
Washer, 10.5mm	1643610	
Washer, 10.5mm	1641100	
Washer, 25x35x2mm	1645130	
Washer, 3/8"	2001050	
Washer, 8.4 mm	1641080	
Washer, M8	1640080	
Weight Tray	6000003	
Wheel Guard Brkt, 8.6	3300001	
Wheel Guard Brkt., 8.7	3300001/HD	
Wheel Guard Shaft	6413153	
Wheel Guard Stop, Ext.Adj.	3300056	
Wheel Guard Stop, int.	1745207	
Wheel Guard Switch	4402102	
Wheel Guard, 8.6	6000002	
Wheel Guard, 8.7	6000002/A	
Width Potentiometer, 10k	3870633	
Wingnut Body	6409018	

PARTS IN NUMERICAL ORDER

<u>PART NUMBER</u>	<u>DESCRIPTION</u>	<u>COMMENTS</u>
1001035/2	Fuse, .4A-250V Quick Act.	
1001035/2	Fuse, .4A-250V Quick Act.	
1001036/4	Fuse, 12A-250V Quick Act.	
1001036/4	Fuse, 12A-250V Quick Act.	
1040901	Distance Gauge Rod	
112296	Alloy Wheel Protective Ring	
112297	Special Hex Wrench, 14mm	
112298	Quick-Nut Clamping Assy.	
112301	Clamping Hood	
112312	Handle	
1230801	Fine Wire Rope	
1230901	Roller (Pulley)	
1235528	Gear Wheel, Potentiometer	
1235533	Gear Wheel, Shaft	
1235535	Gear Wheel	
1317060	Ball Bearing – 6mm dia.	
1317150	Ball Bearing–15mm dia.	
1323600	Fiber Disc, Sliding	
1324032	Collar and Bushing	
1524077	Allen Screw, M10	
1529021	Ch.Hd. Screw, M4x10	
1530117	Hex Screw, M10x20mm	
1530121/A	Adj. Screw, transducer	
1530128	HH Bolt, M10x60mm	
1532662	Self Tap Screw, M6x12mm	
1535060	Allen Screw, M8x16mm	
1552080	Half Nut, M8	
1555060	Nut, M6	
1555100	Nut, M10	
1556100	M10 Hex Nut	
1557101	Self Locking Nut, M10	
1611128	Compression Spring, Jaws	
1613224	Compression Spring	
1614009	Circular Spring	
1614015	Leg Spring	
1621083	Tension Spring	
1621176	Spring	
1631040	Trip Cam	
1640080	Washer, M8	
1641080	Washer, 8.4 mm	
1641100	Washer, 10.5mm	
1643610	Washer, 10.5mm	
1645124	Spacer	
1645130	Washer, 25x35x2mm	
1645148	Disc, Spring Seat	
1645154	Thrust Spacer Ring	
1647100	M10 Lockring	
1648953	Encoder Disc	
1656052	Snap Ring	
1657027	Circlip	
1658060	Circlip	
1659025	Circlip	
1701009	Carriage	
1701012	Steel Washer	

PART NUMBER	DESCRIPTION	COMMENTS
1701355	Bushing	
1701356	Bushing	
1701409	Spring Centering Ring	
1701552	Joined Head	
1701553	Drive Arm	
1745207	Wheel Guard Stop, int.	
2001016	Self Tapping Screw	
2001023	Set Screw, 5/16x18x0.5"	
2001040	Lock Nut	
2001041	Washer	
2001041	Washer, 1/4"	
2001050	Washer, 3/8"	
2001098	Washer	
2001099	HH Bolt, Encoder	
2001107	Set Screw, 3/8x16x1.5"	
2001108	Button Head Screw	
3300001	Wheel Guard Brkt, 8.6	
3300001/HD	Wheel Guard Brkt., 8.7	
3300008	Warning Label	
3300010	Warning Label	
3300017/hd	Drive Belt	
3300022	OFF / ON Switch	
3300025	Motor Mount, Special	
3300050	Location Brake Device	
3300050	Location Brake Device	
3300052	Screw, 1/4-20x 3/4"	
3300053	Panel (Clip) Nut, 1/4-20	
3300056	Wheel Guard Stop, Ext.Adj.	
3300059	Spacer Block, Encoder	
3350113	Interface PCB Fuse .8A	
3350312	Processor Fuse, 1A SB	
3402245	Main Key Pad	
3402246	START Key	
3402247	STOP Key	
3440068	Relay	
3440068	Relay	
3501435/2	Transformer, 230-21VAC	
3501435/2	Transformer, 230-21VAC	
3762010/4	Start Cap, 43-52μF, 330V	
3762010/4	Start Cap, 43-52μF, 330V	
3870633	Width Potentiometer, 10k	
4082727	Distance Gauge Decal	
4104280/6	Motor, 230VAC 1Ph.	
4402102	Wheel Guard Switch	
6000001/A	Front Panel Assembly	
6000002	Wheel Guard, 8.6	
6000002/A	Wheel Guard, 8.7	
6000003	Weight Tray	
6000004	Display Enclosure	
6409018	Wingnut Body	
7409019 7409020	Clamp Jaws, Set	
6410509	Transducer	
6411262	Distance Gauge Lever	
6411559	Drive Pulley	
6413153	Wheel Guard Shaft	
6413155	Calibration Weight	
6415529	Suspension Weldment	
6415551-1	Motor Pulley	

<u>PART NUMBER</u>	<u>DESCRIPTION</u>	<u>COMMENTS</u>
6704143	Encoder	
6726320	Processor PCB	
6726337-2	Interface PCB	
6726352-1	Display PCB	
6726365/4	Motor/Electric Control PCB	
6726365/4	Motor/Electric Control PCB	
6740095-4	EPROM Set	
6740095-4	EPROM Set	
6790493	Distance Potentiometer	
6790494	Diameter Potentiometer	
9500001/A	Rim Width Gauge Arm	
9500003/A	Rim Width Cable Conn.	
9500008	Rim Width Gauge Finger	
9500009	Distance Gauge Finger	
S413503/1	Bracket	

